

THERMOWISE RECIRCULATING DOMESTIC RANGE
Air to Water Heat Pumps

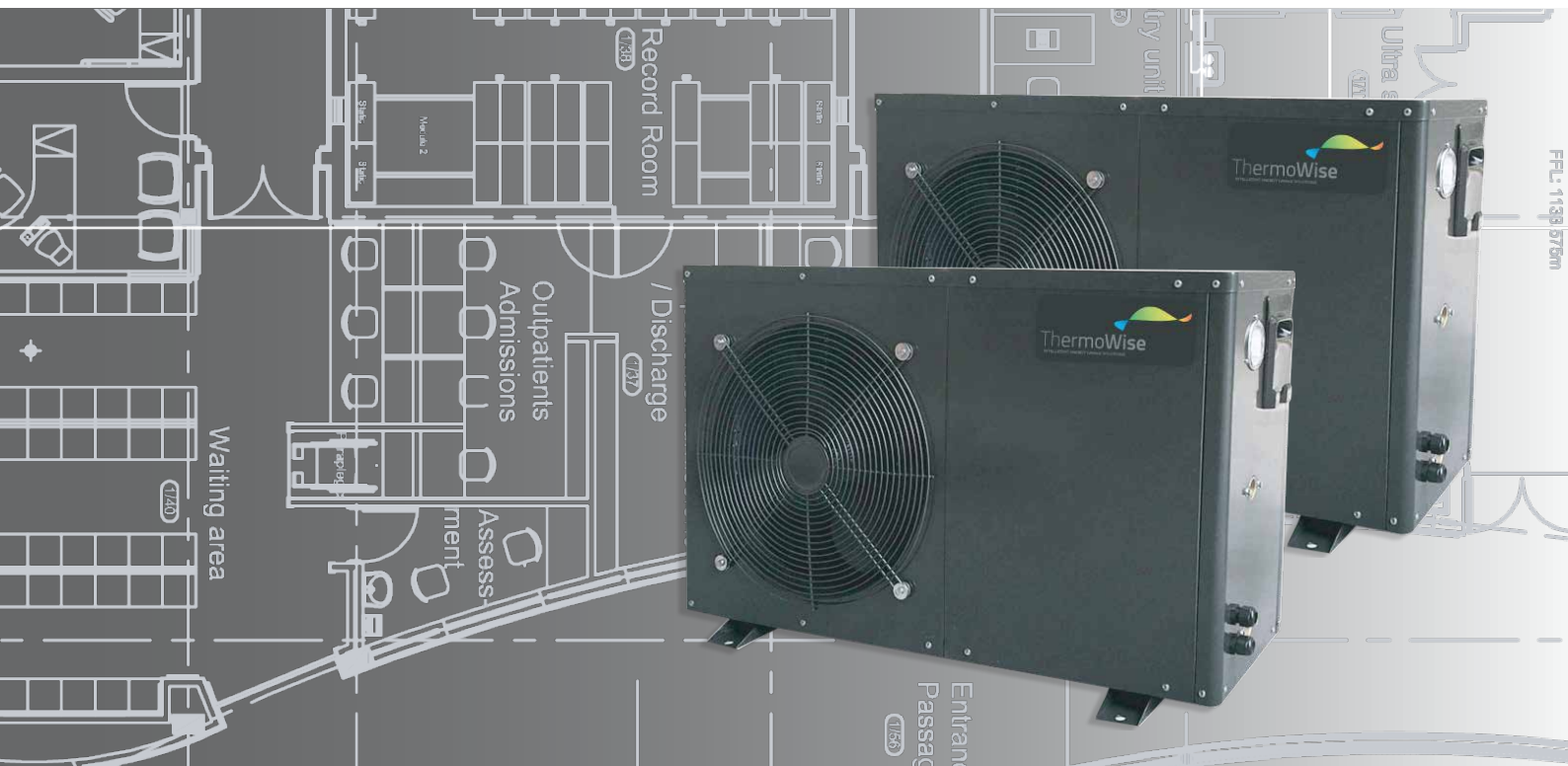

VISSSMANN GROUP

AIR TO WATER HEAT PUMPS RECIRCULATING DOMESTIC RANGE 55°C UNITS SPECIFICATION SHEET



ENERGY EFFICIENT MECHANICAL TURNKEY SOLUTIONS

THERMOWISE RECIRCULATING DOMESTIC RANGE

Air to Water Heat Pumps

ThermoWise Life Cycle Costing Study.

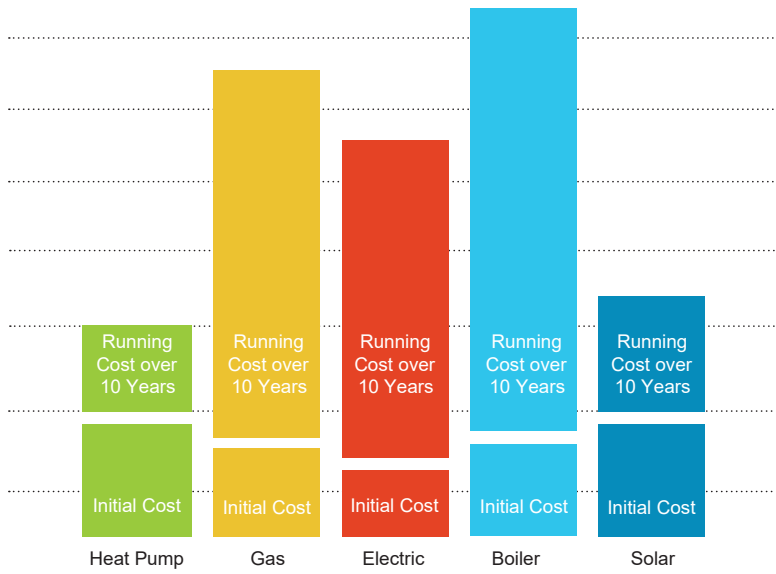

RECIRCULATING DOMESTIC TKRS RANGE ADVANTAGES

- COMMERCIAL
- INDUSTRIAL
- AGRICULTURAL

ThermoWise Energy Use Consumption.

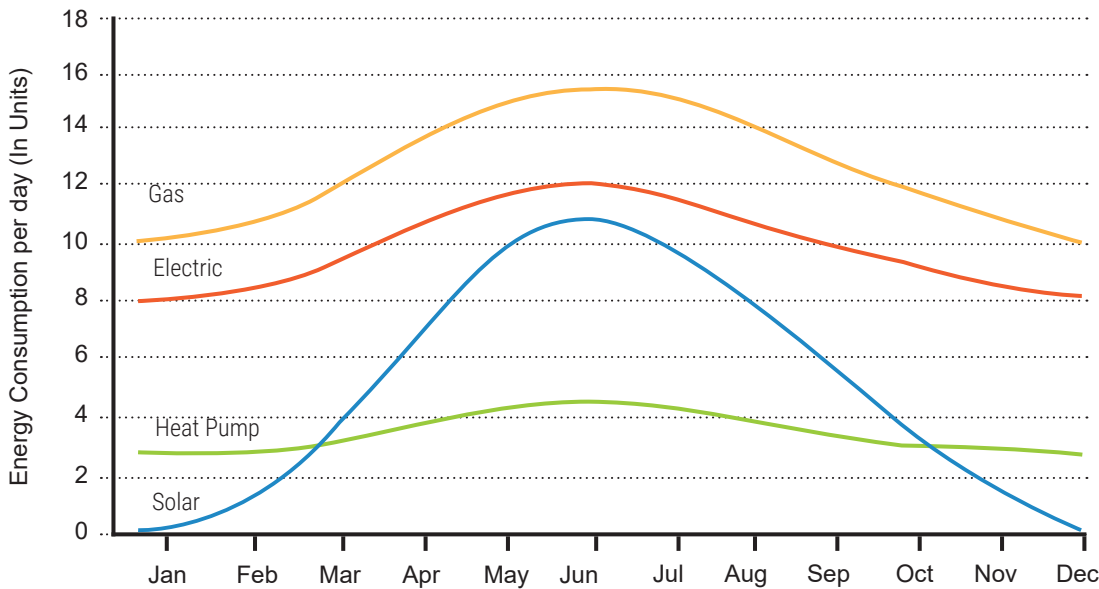

ENERGY EFFICIENT MECHANICAL TURNKEY SOLUTIONS

KZN OFFICE

0860 HEAT H20 / 0860 4328 420
 TEL +27 32 947 0377 FAX +27 32 947 0349
 CNR UMKHOBBA & UMZITHI RD, ETETE, DOLPHIN COAST
 SHAKASRAAL, 4430

GAUTENG OFFICE

0860 HEAT H20 / 0860 4328 420
 TEL +27 11 450 1418 FAX +27 86 602 0311
 88 DRIEHOEK ROAD, GERMISTON 1401,
 JOHANNESBURG

P O BOX 6980, ZIMBALI 4418, SOUTH AFRICA
 info@thermowise.co.za / www.thermowise.co.za



INDEX

DOMESTIC

COMMERCIAL

INDUSTRIAL

AGRICULTURAL

Page 1	Domestic Unit TKRS-03 / 3.5kW Range Specification
Page 2	Domestic Unit TKRS-03/05/07 Features and Benefits
Page 3	Domestic Unit TKRS-03 / 3.5kW Exploded View and Dimensional Layout
Page 4	Domestic Unit TKRS-05 / 5.2kW Range Specification
Page 5	Domestic Unit TKRS-05 / 5.2kW Exploded View and Dimensional Layout
Page 6	Domestic Unit TKRS-07 / 7.2kW Range Specification
Page 7	Domestic Unit TKRS-07 / 7.2kW Exploded View and Dimensional Layout
Page 8	Domestic Unit TKRS -03/05/07 ThermoWise Installation Kit
Page 9	Domestic Unit TKRS Installation Schematic





FEATURES AND BENEFITS

WIDE RANGE OF APPLICATIONS

The Thermowise heat pump is designed for commercial buildings such as small hotels, offices, schools, hospitals, apartments etc. as well as domestic hot water for houses. The hot water outlet range is wide from 20 to 60, meeting demands for most hot water projects. With the performance at a wide ambient temperature range from -10~43°C. Modular control systems are available to meet the demands of bigger hot water projects.

Our Heat Pump is designed for high efficiency performance over a lifetime of operation with the annual average COP of up to 4.5. The water pipes and refrigerant pipes are well insulated to minimize heat loss.

DURABLE AND LONG LIFE

High efficiency compressors are in all units, with durable features against high temperatures and high pressures ensuring a long life. The tube in shell heat exchanger is durable withstanding corrosion, hard water, high pressure and unexpected freezing caused by power loss.

STRONG CABINET

The standard unit fabrication consists of a heavy gage galvanized sheet metal cabinet construction that provides maximum strength. All interior sheet metal surfaces are Electrophoresis treated in advance and powder-painted for maximum corrosion protection to ensure resilience for long term vitality.

NOISE CONTROL

Compressor rubber feet are specially selected for reducing vibration and a compressor sound jacket is available for every unit. Well-balanced fans and fan motors, with the optimized fan holder, contributes to the low noise operation. The cabinet inside is also insulated to reduce noise transmission.

RELIABLE AND SAFE DESIGN

Standard safety features for the refrigerant circuit include a high-pressure switch and low-pressure switch to detect loss the of refrigerant, as well as deficient water flow. Equipment safety features include water loop temperature monitoring, voltage protection and water coil freeze protection. All safety features are tested and run at the factory to en-sure proper operation of all components and safety switches.

All components are carefully designed and selected for endurance and durability with each unit fully tested in performance and safety before leaving the factory.

SIMPLE MAINTENANCE

Full access for maintenance and service is provided from the service panel allowing for better flexibility in confined spaces. Easy removal of the control box from the unit provides access to all refrigerant components. The refrigerant circuit is easily tested and serviced through the use of high and low pressure ports integral to the refrigerant circuit.



MODEL NO: TKRS-03

INPUT 0.9kW / OUTPUT 3.6kW



Model			TKRS-03
Heating	Capacity	KW	3.6
	Power input	KW	0.9
	COP	W/W	4.7

Power supply	V/Ph/Hz	AC-220-240V/1Ph/50Hz
Max. leaving water temperature (without using backup heater)	°C	55
Rated water yield	L/H	81
Running temperature range	°C	-10 / 55
Refrigerant type		R410A
Compressor		PANASONIC/ROSHIBA/Rotary
Max Current		6.0A
Water circuit Heat exchanger		Tube in shell heat exchanger
Net Dimensions (HxWxD)	mm	935x397x595
Packing Dimensions (HxWxD)	mm	1060x380x630
Net Weight	Kg	48
Gross Weight	Kg	55

Heating Capacity Curves

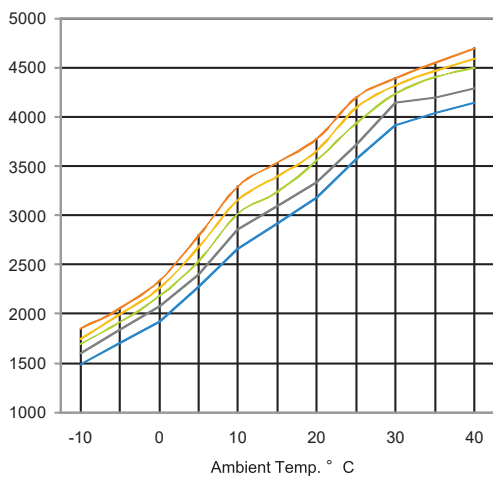

COP Curves

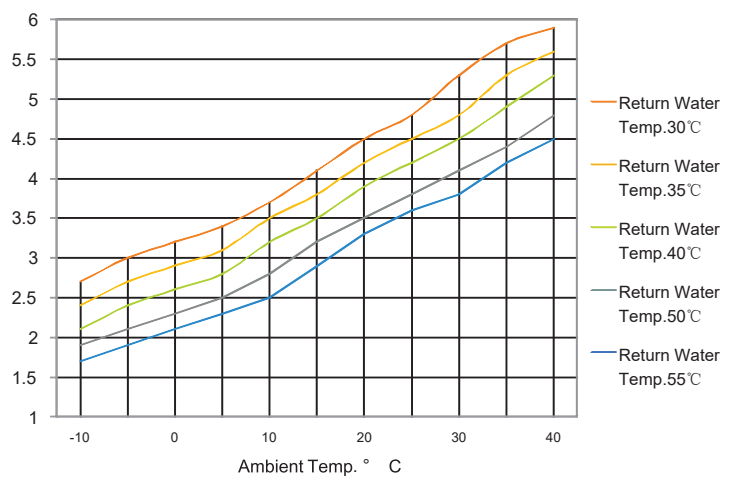



MODEL NO: TKRS-03 EXPLODED VIEW

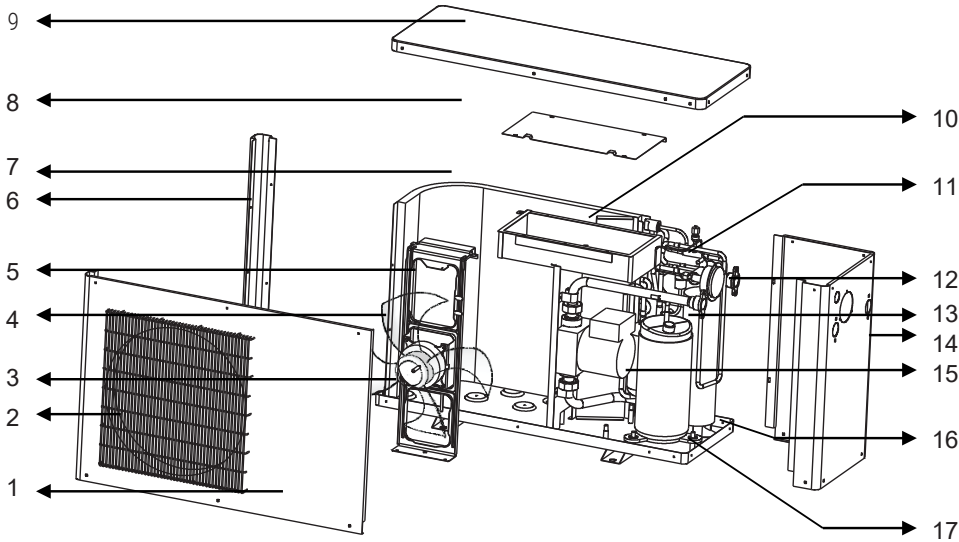

No.	Description
1	Left front plate
2	Air outlet grill
3	Fan motor
4	Fan
5	Fan motor holder
6	Back holder
7	Condenser
8	Electrical box cover
9	Top plate
10	Electrical box
11	Four-way valve assembly
12	Manometer
13	Pressure relief valve
14	Right plate
15	Water pump
16	Shell & tube heat exchanger
17	Compressor

DIMENSIONAL LAYOUT

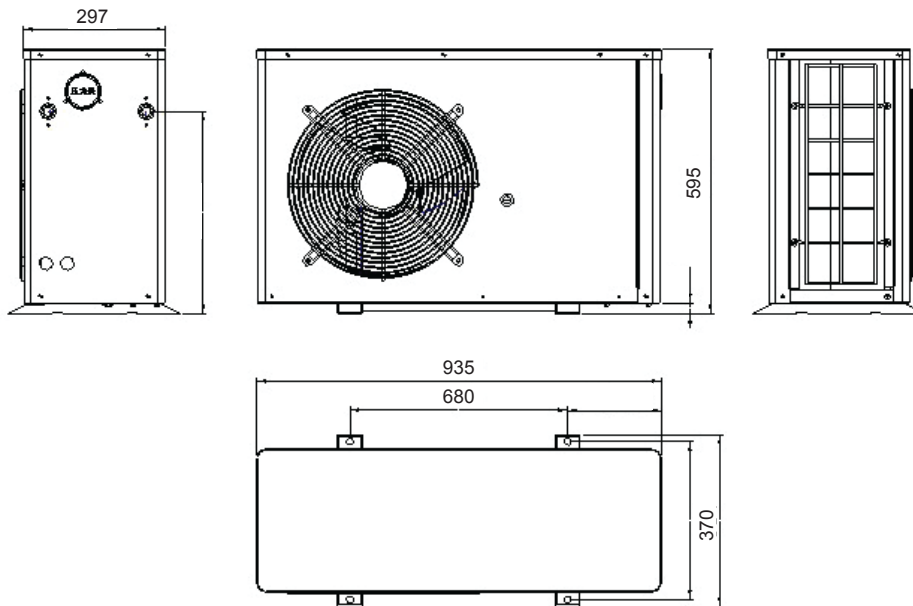

THERMOWISE RECIRCULATING DOMESTIC RANGE

Air to Water Heat Pumps



MODEL NO: TKRS-05

INPUT 1.2kW / OUTPUT 5.2kW



Model			TKRS-05
Heating	Capacity	KW	5.2
	Power input	KW	1.2
	COP	W/W	4.5

Power supply	V/Ph/Hz	AC-220-240V/1Ph/50Hz
Max. leaving water temperature (without using backup heater)	°C	55
Rated water yield	L/H	112
Running temperature range	°C	-10/55
Refrigerant type		R410A
Compressor		PANASONIC/TOSHIBA/Rotary
Max Current		9.0A
Water circuit Heat exchanger		Tube in shell heat exchanger
Net Dimensions (HxWxD)	mm	550x976x300
Packing Dimensions (HxWxD)	mm	600x1010x330
Net Weight	Kg	53.5
Gross Weight	Kg	55

Heating Capacity Curves

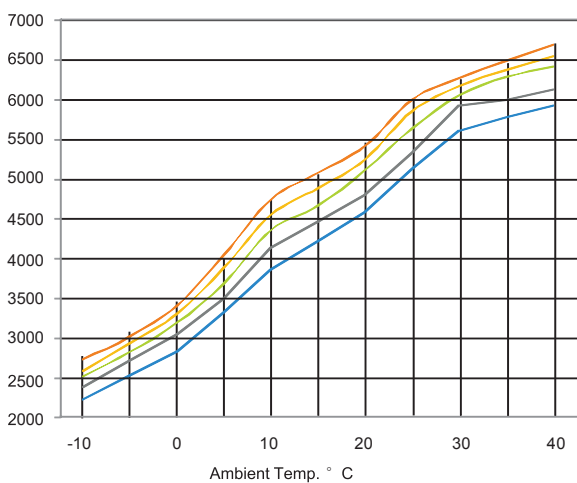

COP Curves

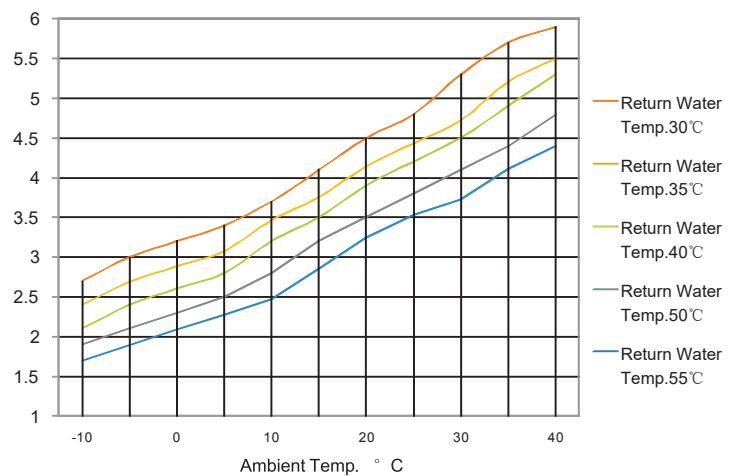



MODEL NO: TKRS-05 EXPLODED VIEW

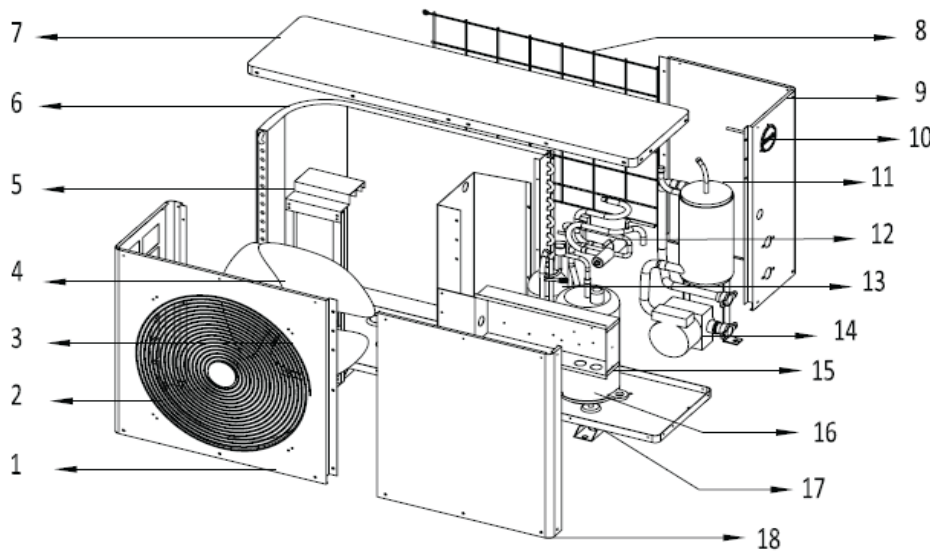

No.	Description
1	Left front plate
2	Air outlet grill
3	Fan motor
4	Fan
5	Fan motor holder
6	Condenser
7	Top plate
8	Rear net
9	Right plate
10	Manometer
11	Shell & tube heat exchanger
12	Four-way valve assembly
13	Pressure relief valve
14	Water pump
15	Electrical box
16	Compressor
17	Base assembly
18	Right front plate

DIMENSIONAL LAYOUT

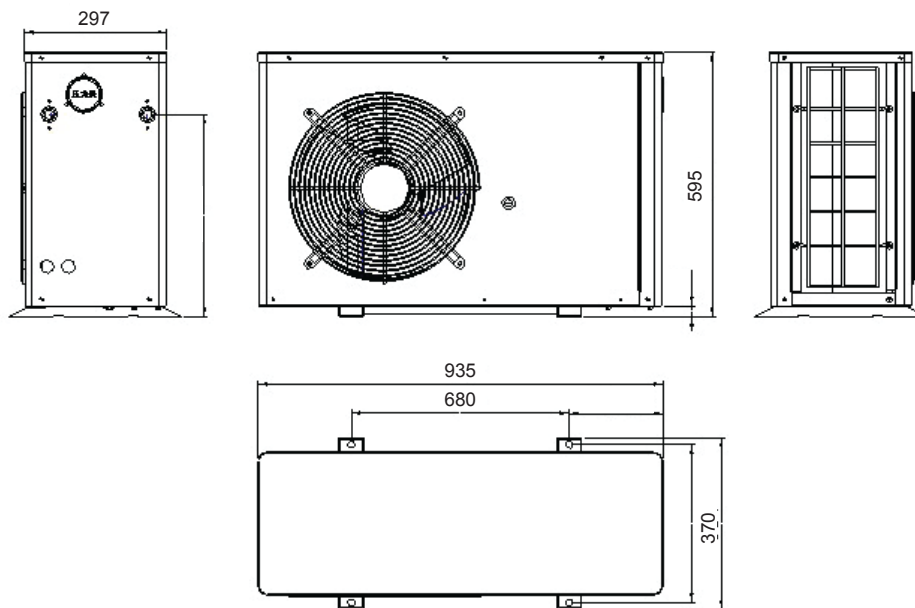



MODEL NO: TKRS-07

INPUT 1.8kW / OUTPUT 7.2kW



Model			TKRS-07
Heating	Capacity	KW	7.2
	Power input	KW	1.8
	COP	W/W	4.3

Power supply	V/Ph/Hz	AC-220-240V/1Ph/50Hz
Max. leaving water temperature (without using backup heater)	°C	55
Rated water yield	L/H	160
Running temperature range	°C	-10 / 55
Refrigerant type		R410A
Compressor		PANASONIC/TOSHIBA/Rotary
Max Current		12.0A
Water circuit Heat exchanger		Tube in shell heat exchanger
Net Dimensions (HxWxD)	mm	550x976x300
Packing Dimensions (HxWxD)	mm	600x1010x330
Net Weight	Kg	57
Gross Weight	Kg	64

Heating Capacity Curves

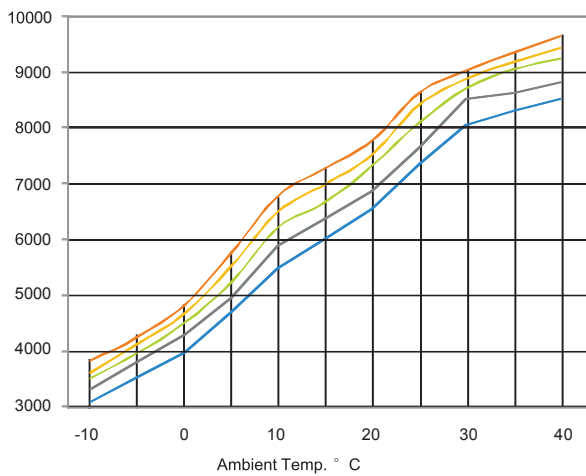

COP Curves

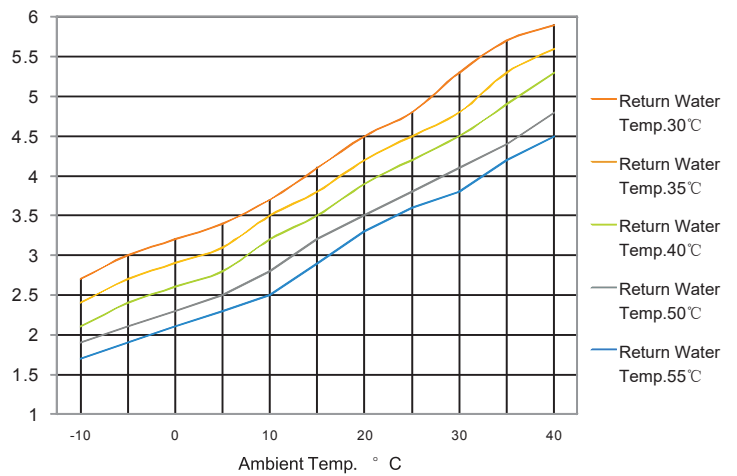



MODEL NO: TKRS-07 EXPLODED VIEW

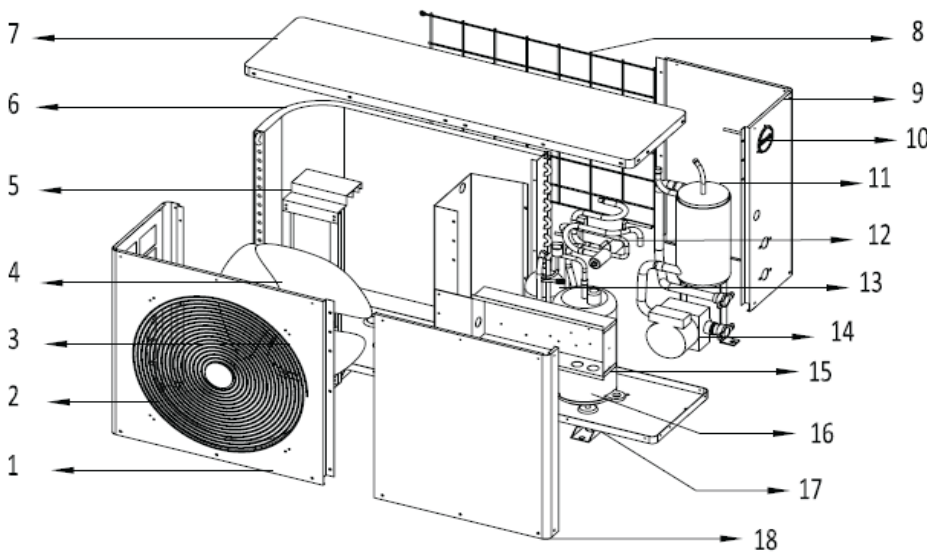

No.	Description
1	Left front plate
2	Air outlet grill
3	Fan motor
4	Fan
5	Fan motor holder
6	Condenser
7	Top plate
8	Rear net
9	Right plate
10	Manometer
11	Shell & tube heat exchanger
12	Four-way valve assembly
13	Pressure relief valve
14	Water pump
15	Electrical box
16	Compressor
17	Base assembly
18	Right front plate



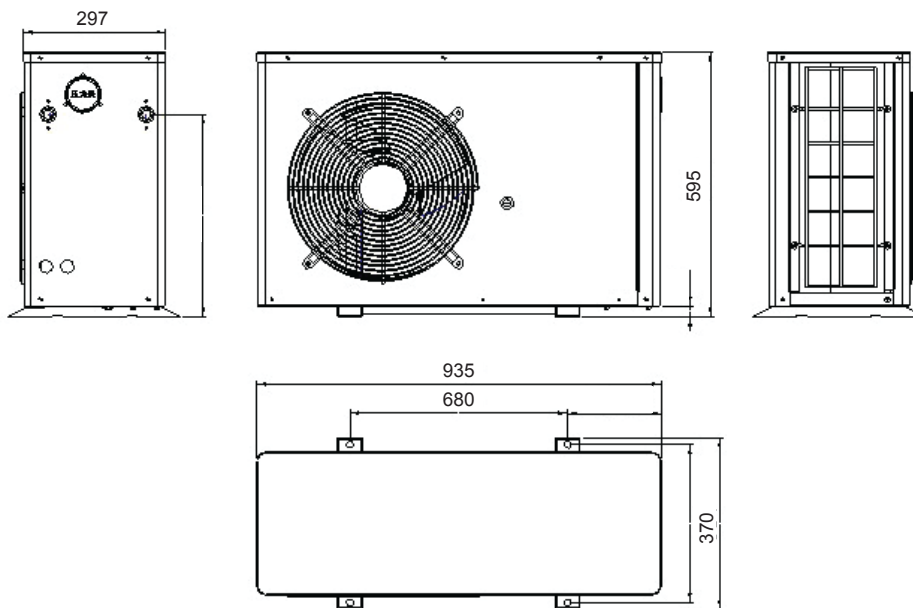



DIMENSIONAL LAYOUT



THERMOWISE INSTALLATION KIT

FOR: MODEL NO: TKRS-03
 MODEL NO: TKRS-05
 MODEL NO: TKRS-07

The ThermoWise Installation Kit consists of the following materials:

QTY	PRODUCT NAME	DESCRIPTION	PRODUCT IMAGE
1	Strainer	Due to the sensitive nature of the heat pumps with regards to optimum required water flow rate, it is of the utmost importance to minimize restrictions where possible.	
2	Lever Ball Valve	Must be the full bore type.	
1	Dual Drain-cock	In ThermoWise units the sensor is fitted inside the heat pump by the factory. These units will not require a probe pocket on the drain-cock and a normal solar drain cock can be used.	
1	Banjo Valve	To be used on retrofit installations. It makes available an extra port on the geyser to use for the heat pump installation. On new geyser heat pump installations we recommend the use of a heat pump compatible geyser. In such a case no banjo valve will be required.	
1	Diffuser Pipe (Pex Pipe)	The use of the PEX diffuser pipe will be needed on all retrofit installations. The purpose of this pipe is to prevent major upset of the stratification layers but more importantly to prevent short cycling between the outlet of the unit where it is connected to the geyser and the hot water outlet to building. These two ports will on most vessels be very close to each other. The diffuser pipe used must be rated to operate in high temperature conditions and must not lose its rigidity.	
1 Set	Powder Coated Brackets (Optional extra - Galvanised Brackets)	Brackets are preferred to be of the galvanized type especially in coastal regions and must have a bearing weight capable to handle the weight of the heat pump. Preferably 3 times the weight of the unit.	
1	Conex Reducer	22mmx15mm conex reducer This fitting is to be used when installing the pex pipe diffuser into the tank.	



INSTALLATION SCHEMATIC

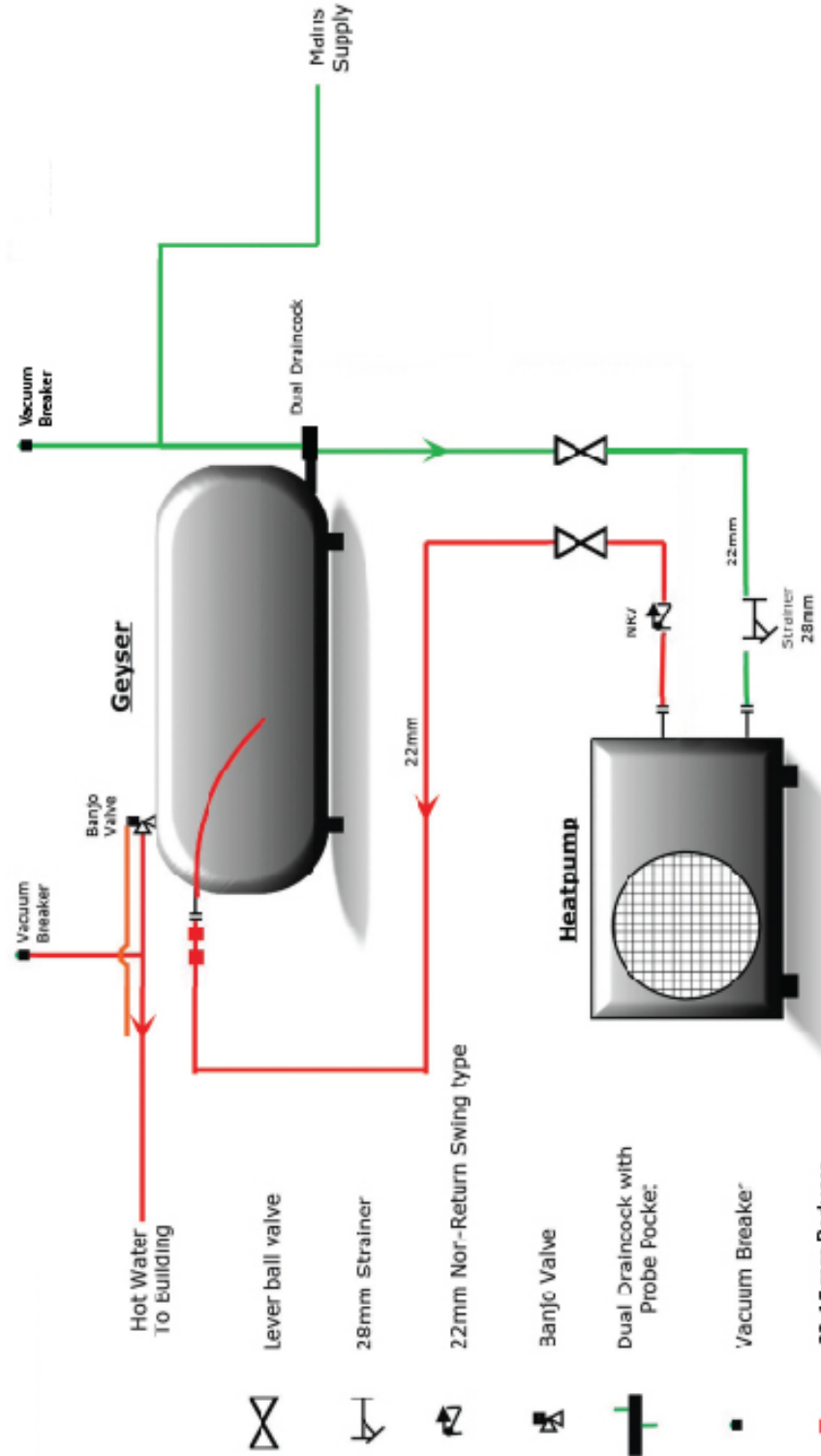

Single Connection

**WE CAN CREATE A
MORE SUSTAINABLE,
CLEANER AND SAFER
WORLD BY MAKING
WISER ENERGY
CHOICES.**

-ROBERT ALAN

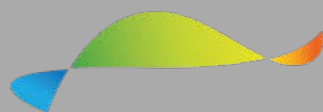

ThermoWise
INTELLIGENT ENERGY SAVING SOLUTIONS

VISSMANN GROUP